

datavideo

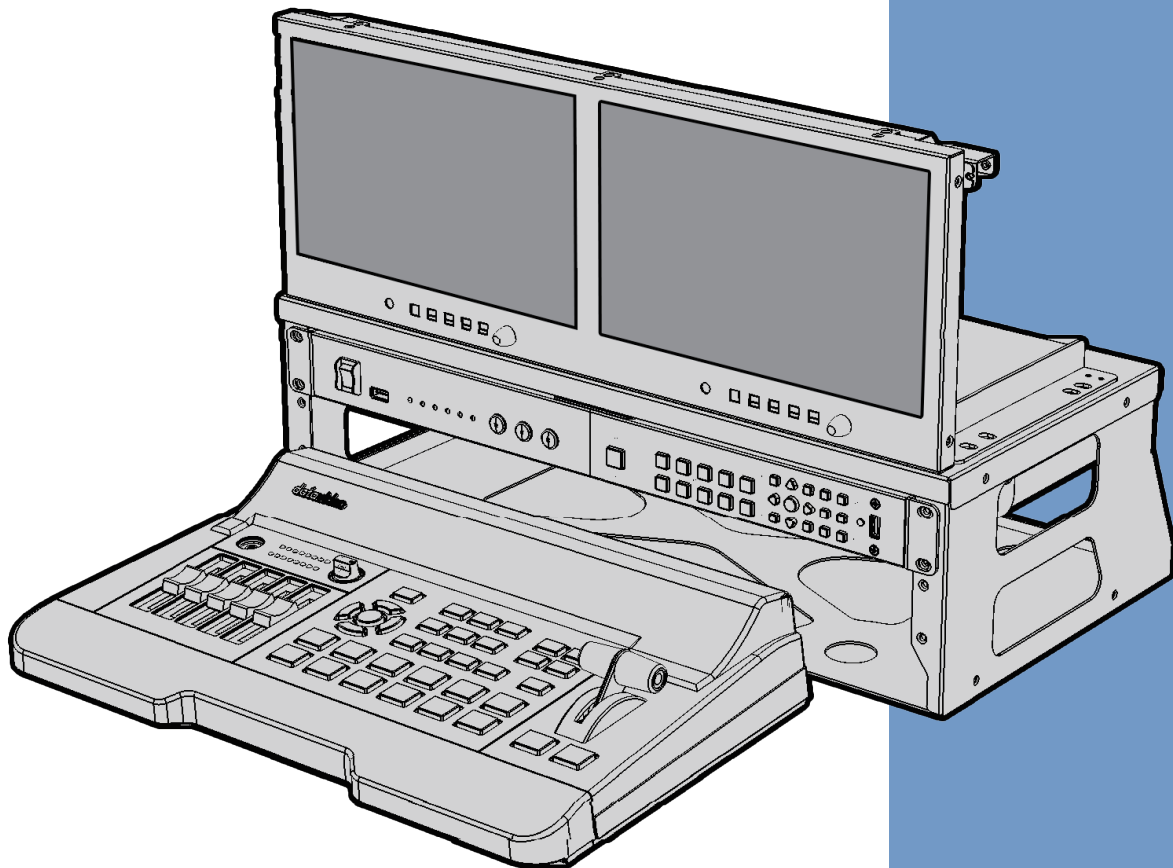

**4 CHANNEL HD/SD PORTABLE
VIDEO PRODUCTION STUDIO**

GO 500 STUDIO

Instruction Manual

www.datavideo.com

Contents

FCC COMPLIANCE STATEMENT	3
WARNINGS AND PRECAUTIONS	3
WARRANTY	4
STANDARD WARRANTY	4
THREE YEAR WARRANTY	4
DISPOSAL	4
INTRODUCTION	5
FEATURES.....	5
GO-500 STUDIO	6
INSTALLATION	7
TRANSPORT & PLACEMENT.....	7
OPENING THE CASE	7
SETTING UP THE TLM-102 – DUAL 10.1” LCD MONITOR.....	7
HOW TO CONNECT INTERNAL CABLES	8
POWERING ON	12
POWERING OFF	12
PACKING AWAY	12
DIMENSIONS	13
WEIGHTS	14
SPECIFICATIONS	14
NOTE	15
SERVICE & SUPPORT	16

Disclaimer of Product and Services

The information offered in this instruction manual is intended as a guide only. At all times, Datavideo Technologies will try to give correct, complete and suitable information. However, Datavideo Technologies cannot exclude that some information in this manual, from time to time, may not be correct or may be incomplete. This manual may contain typing errors, omissions or incorrect information. Datavideo Technologies always recommend that you double check the information in this document for accuracy before making any purchase decision or using the product. Datavideo Technologies is not responsible for any omissions or errors, or for any subsequent loss or damage caused by using the information contained within this manual. Further advice on the content of this manual or on the product can be obtained by contacting your local Datavideo Office or dealer.

FCC Compliance Statement

This device complies with part 15 of the FCC rules. Operation is subject to the following two conditions:

1. This device may not cause harmful interference, and
2. This device must accept any interference received, including interference that may cause undesired operation.

Warnings and Precautions



The GO-500 STUDIO is HEAVY – approximately 16.07 Kg. Two or more people are required to move this unit.

The GO-500 STUDIO should be always moved and placed in a horizontal position; do not place or try to move the unit in any other position as damage or injury could result.

Always use a trolley to safely transport the unit over distances of 2 metres or more.

1. Read all of these warnings and save them for later reference.
2. Follow all warnings and instructions marked on this unit.
3. Unplug this unit from the wall outlet before cleaning. Do not use liquid or aerosol cleaners. Use a damp cloth for cleaning.
4. Do not use this unit in or near water.
5. Do not place this unit on an unstable cart, stand, or table. The unit may fall, causing serious damage.
6. Slots and openings on the cabinet top, back, and bottom are provided for ventilation. To ensure safe and reliable operation of this unit, and to protect it from overheating, do not block or cover these openings. Do not place this unit on a bed, sofa, rug, or similar surface, as the ventilation openings on the bottom of the cabinet will be blocked. This unit should never be placed near or over a heat register or radiator. This unit should not be placed in a built-in installation unless proper ventilation is provided.
7. This product should only be operated from the type of power source indicated on the marking label of the AC adapter. If you are not sure of the type of power available, consult your Datavideo dealer or your local power company.
8. Do not allow anything to rest on the power cord. Do not locate this unit where the power cord will be walked on, rolled over, or otherwise stressed.
9. If an extension cord must be used with this unit, make sure that the total of the ampere ratings on the products plugged into the extension cord do not exceed the extension cord rating.
10. Make sure that the total amperes of all the units that are plugged into a single wall outlet do not exceed 15 amperes.
11. Never push objects of any kind into this unit through the cabinet ventilation slots, as they may touch dangerous voltage points or short out parts that could result in risk of fire or electric shock. Never spill liquid of any kind onto or into this unit.
12. Except as specifically explained elsewhere in this manual, do not attempt to service this product yourself. Opening or removing covers that are marked “Do Not Remove” may expose you to dangerous voltage points or other risks, and will void your warranty. Refer all service issues to qualified service personnel.
13. Unplug this product from the wall outlet and refer to qualified service personnel under the following conditions:
 - a. When the power cord is damaged or frayed;
 - b. When liquid has spilled into the unit;
 - c. When the product has been exposed to rain or water;
 - d. When the product does not operate normally under normal operating conditions. Adjust only those controls that are covered by the operating instructions in this manual; improper adjustment of

- other controls may result in damage to the unit and may often require extensive work by a qualified technician to restore the unit to normal operation;
- e. When the product has been dropped or the cabinet has been damaged;
- f. When the product exhibits a distinct change in performance, indicating a need for service.

Warranty

Standard Warranty

- Datavideo equipment are guaranteed against any manufacturing defects for one year from the date of purchase.
- The original purchase invoice or other documentary evidence should be supplied at the time of any request for repair under warranty.
- The product warranty period begins on the purchase date. If the purchase date is unknown, the product warranty period begins on the thirtieth day after shipment from a Datavideo office.
- All non-Datavideo manufactured products (product without Datavideo logo) have only one year warranty from the date of purchase.
- Damage caused by accident, misuse, unauthorized repairs, sand, grit or water is not covered under warranty.
- Viruses and malware infections on the computer systems are not covered under warranty.
- Any errors that are caused by unauthorized third-party software installations, which are not required by our computer systems, are not covered under warranty.
- All mail or transportation costs including insurance are at the expense of the owner.
- All other claims of any nature are not covered.
- All accessories including headphones, cables, and batteries are not covered under warranty.
- Warranty only valid in the country or region of purchase.
- Your statutory rights are not affected.

Three Year Warranty

- All Datavideo products purchased after July 1st, 2017 are qualified for a free two years extension to the standard warranty, providing the product is registered with Datavideo within 30 days of purchase.
- Certain parts with limited lifetime expectancy such as LCD panels, DVD drives, Hard Drive, Solid State Drive, SD Card, USB Thumb Drive, Lighting, Camera module, PCIe Card are covered for 1 year.
- The three-year warranty must be registered on Datavideo's official website or with your local Datavideo office or one of its authorized distributors within 30 days of purchase.



Disposal

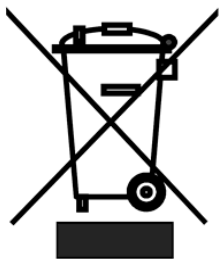

For EU Customers only - WEEE Marking

This symbol on the product or on its packaging indicates that this product must not be disposed of with your other household waste. Instead, it is your responsibility to dispose of your waste equipment by handing it over to a designated collection point for the recycling of waste electrical and electronic equipment. The separate collection and recycling of your waste equipment at the time of disposal will help to conserve natural resources and ensure that it is recycled in a manner that protects human health and the environment. For more information about where you can drop off your

waste equipment for recycling, please contact your local city office, your household waste disposal service or the shop where you purchased the product.



CE Marking is the symbol as shown on the left of this page. The letters "CE" are the abbreviation of French phrase "Conformité Européene" which literally means "European Conformity". The term initially used was "EC Mark" and it was officially replaced by "CE Marking" in the Directive 93/68/EEC in 1993. "CE Marking" is now used in all EU official documents.

Introduction

The Go 500 Studio is a small all-in-one video switcher studio system with foldable dual 10.1" monitor. This compact system can be fit into the HC-800 case as a ready to go system. It offers 4 HDMI inputs that support up to Full HD 1080P.

The system is small but fully equipped with functions such as video switching, video recording, video streaming and etc.

Datavideo offers a complete product line for all studio and education markets.

To get more value out of your equipment, please take a few minutes to read through this overview manual, and the other associated user manuals. This will help you to familiarize yourself with all aspects of the GO-500 STUDIO.

Features

- The System includes the following:
 - Switcher
 - Recorder
 - Streaming server
 - Monitor
- Supports up to Full HD 1080p
- A single power supply powering all integrated devices
- Easy installation

GO-500 STUDIO

Front Panel

TLM-102: Foldable 4RU rack mount dual monitor providing connections for **SDI** and **HDMI** videos.

HDR-1: 1080p30 frame recorder recording to **MP4** file format.

NVS-25: H.264 video streaming server for streaming **HDMI**, **SDI** and **CVBS** videos over the Ethernet network.

SE-500HD: HD/SD digital video switcher offering **4 HDMI inputs** and **2 HDMI outputs**; the switcher supports video formats up to **Full HD 1080p**.

Rear Panel

RMK-6: The LAN port provides **video stream OUT** to destination devices. The **DC IN** socket connects the 12V power and supplies power to all integrated devices. The three HDMI ports act as the output ports for the internal HDMI splitter. The switch acts as a central switch for the entire system.

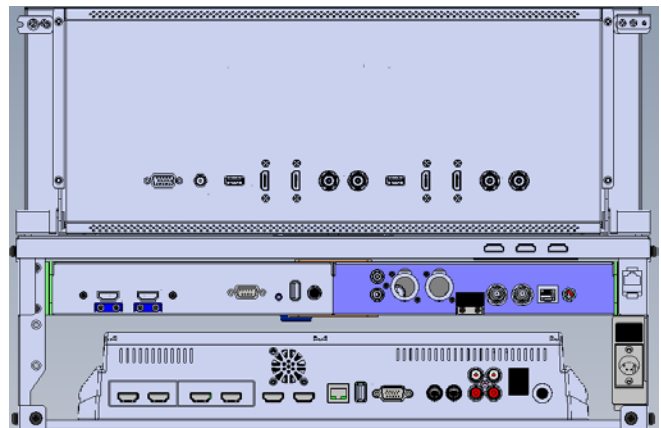
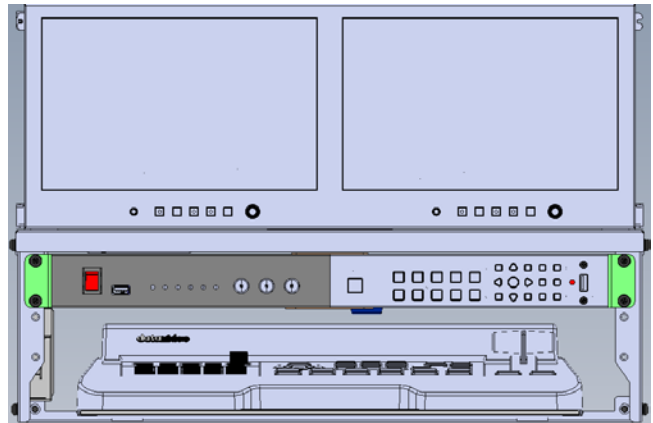

Installation

Transport & Placement

The GO-500 STUDIO is heavy – approximately 16.07 Kg – Do not attempt to lift or move it on your own.

A minimum of two people are required to lift or move this product.

Always use a trolley to safely transport the GO-500 STUDIO over distances of 2 Metres or more. The unit should be always moved and placed in a horizontal position; do not place or try to move the unit in any other way as damage or injury could result.

Place the GO-500 STUDIO on a strong, stable, flat surface that is capable of supporting the weight. Do not use a folding or single leg table to support the GO-500 STUDIO.

Opening the Case

1. Rest the HC-800 on a flat horizontal surface with the carry handle facing the user
2. Open the buckles on two sides of the carry handle.
3. Lift open the cover
4. Remove the GO-500 system from the case.



Setting up the TLM-102 – Dual 10.1” LCD Monitor

1. Bring the LCD panel into an upright viewing position.
2. After that, please refer to following chapter “**How to Connect Internal Cables**” to connect all the cables according to the instructions.
3. After all of the cables are connected properly, just remember to turn on the power switch and then it’s time for you to enjoy the efficiency and the convenience of the GO-500 Studio.

How to Connect Internal Cables

Cable requirements:

- Cable No. 1-4: DC Plug Cable built into the RMK-6 (45 CM)
- Cable No. 6: HDMI Cable (100 CM)
- Cable No. 7: HDMI Cable (100 CM)
- Cable No. 8: HDMI Cable (50 CM)
- Cable No. 9: HDMI Cable (50 CM)
- Cable No. 10: HDMI Cable (50CM)
- Cable No. 11: Ethernet Cable

1. Connect one end of Cable No. 11 (Ethernet Cable) to LAN OUT on the rear panel of the NVS-25 and another end to the RMK-6 RACK's RJ-45 Port on the inner side as indicated by the red arrow shown in the diagram below.

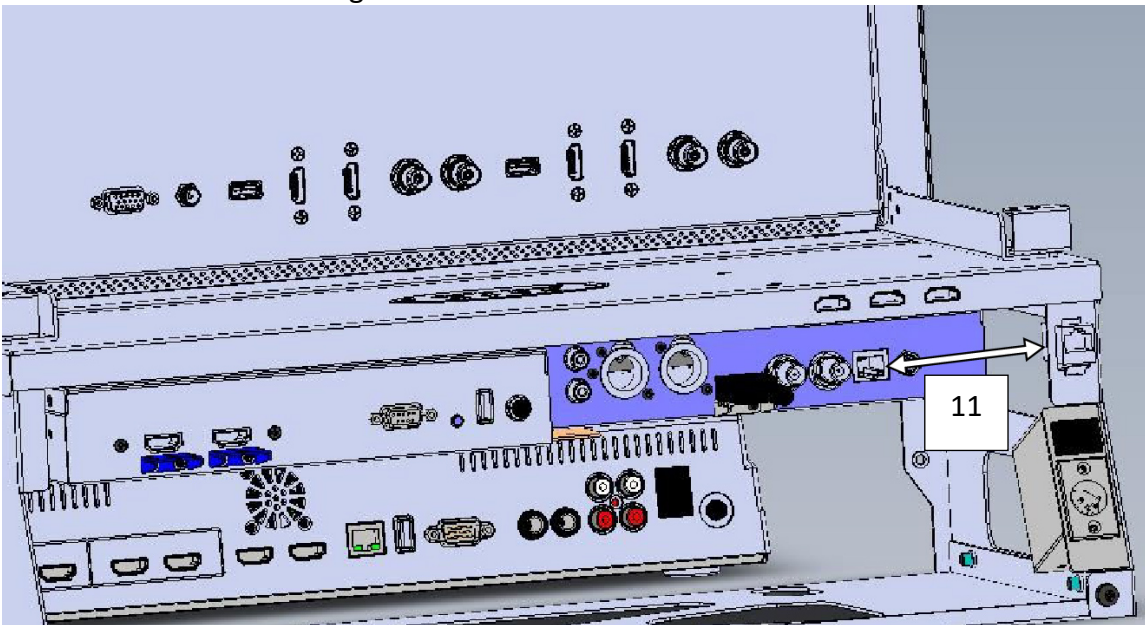

2. Connect one end of Cable No. 10 (50CM HDMI Cable) to NVS-25 HDMI IN and another end to HDMI Splitter HDMI OUT.

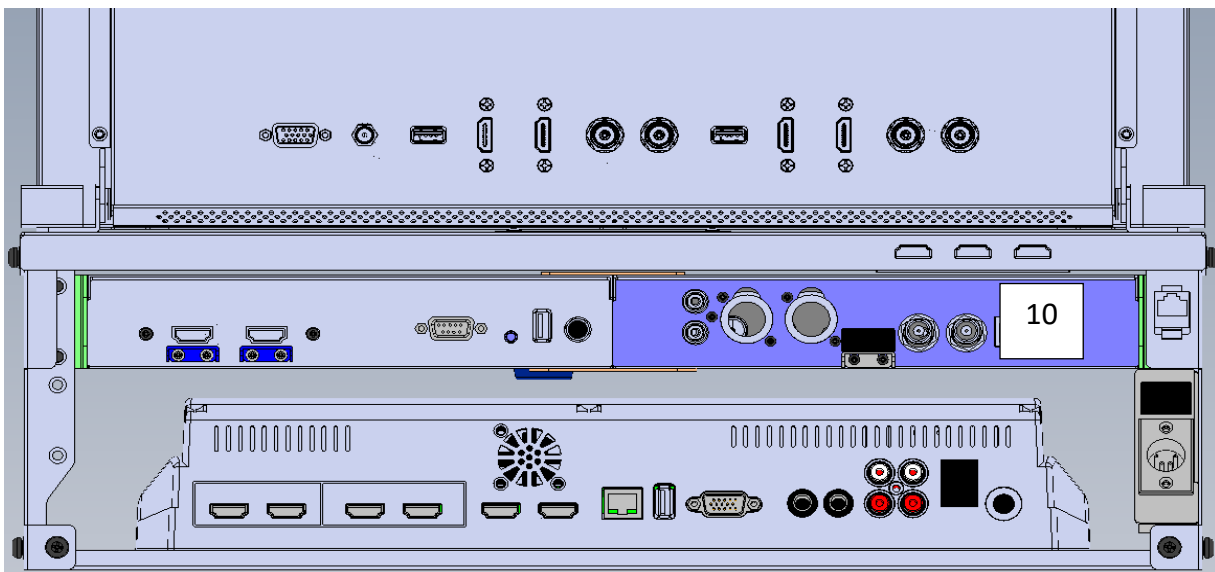

3. Connect one end of Cable No. 7 (100CM HDMI Cable) to TLM-102 HDMI IN1 and another end to SE-500HD Multiview.

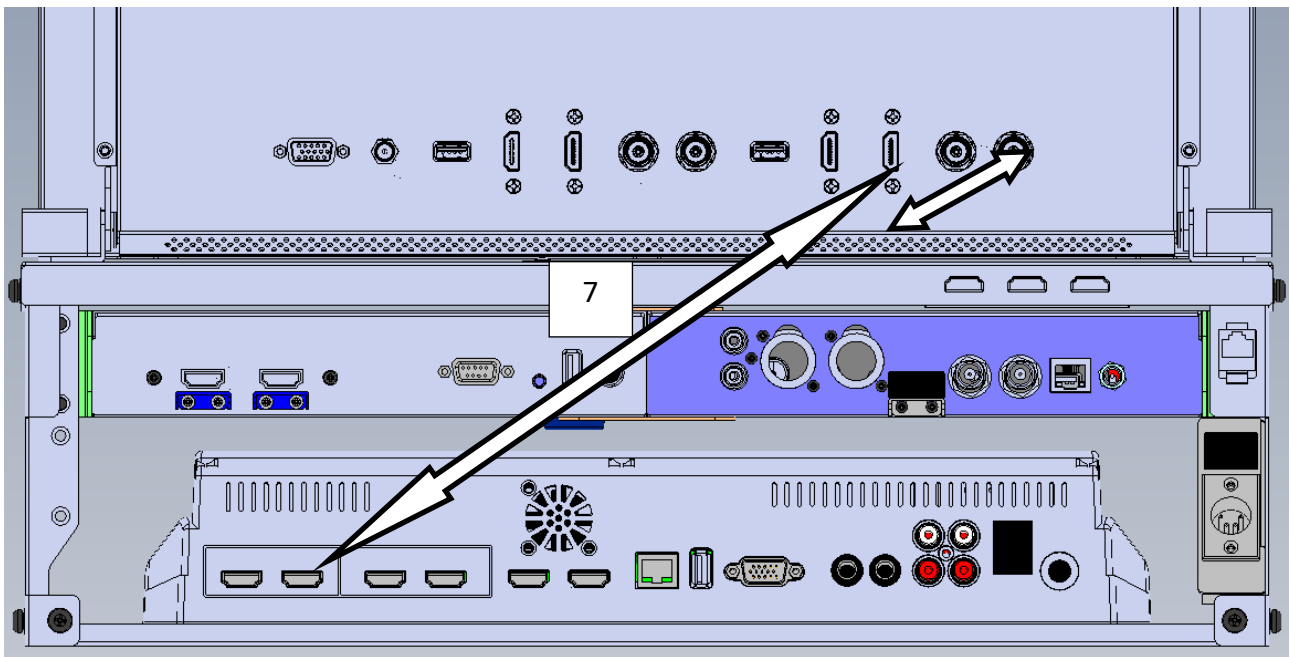

4. Connect one end of Cable No. 6 (100 CM HDMI Cable) to HDMI IN of the internal HDMI splitter and another end to SE-500HD PROGRAM port.

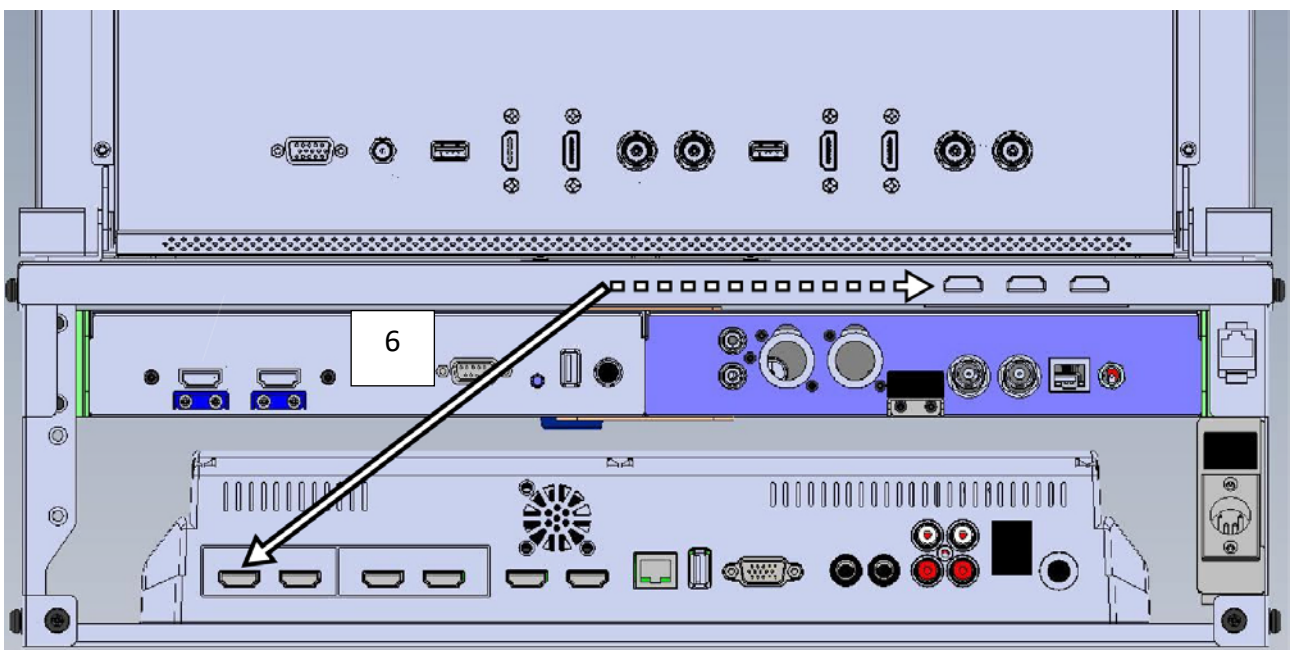

5. Connect one end of Cable No. 9 (50 CM HDMI Cable) to HDR-1 HDMI OUT and another end to TLM-102 HDMI IN2.

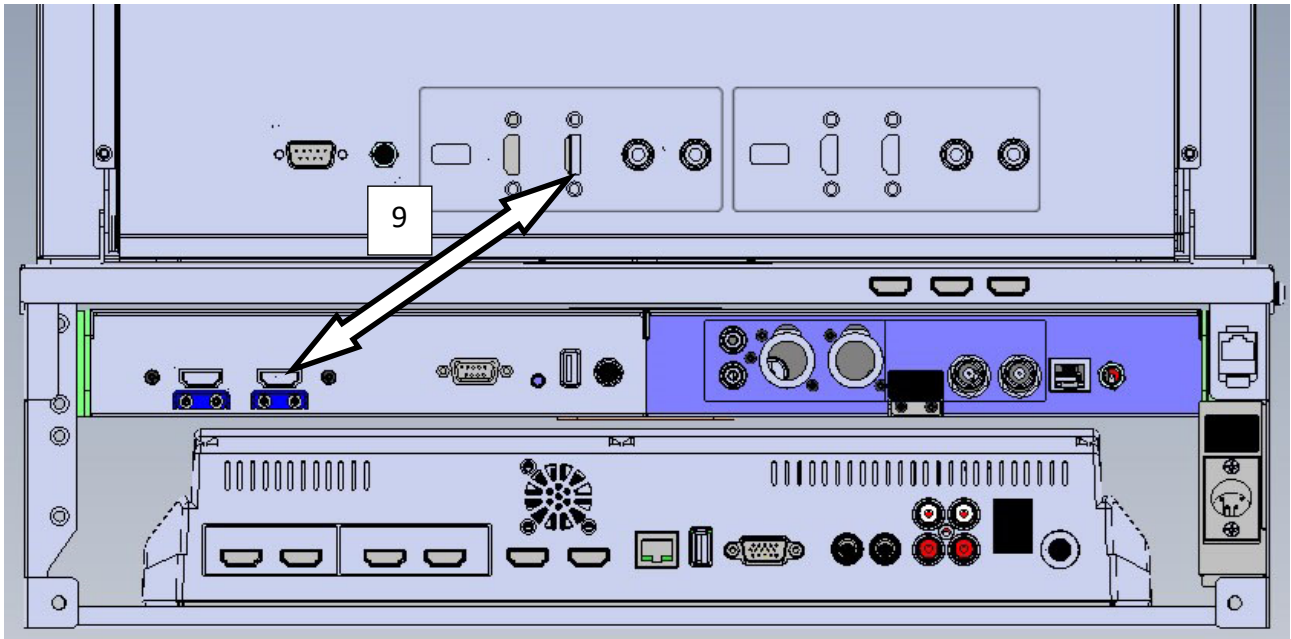

6. Connect one end of Cable No.8 (50 CM HDMI Cable) to HDR-1 HDMI IN and another end to HDMI OUT of the internal HDMI splitter.

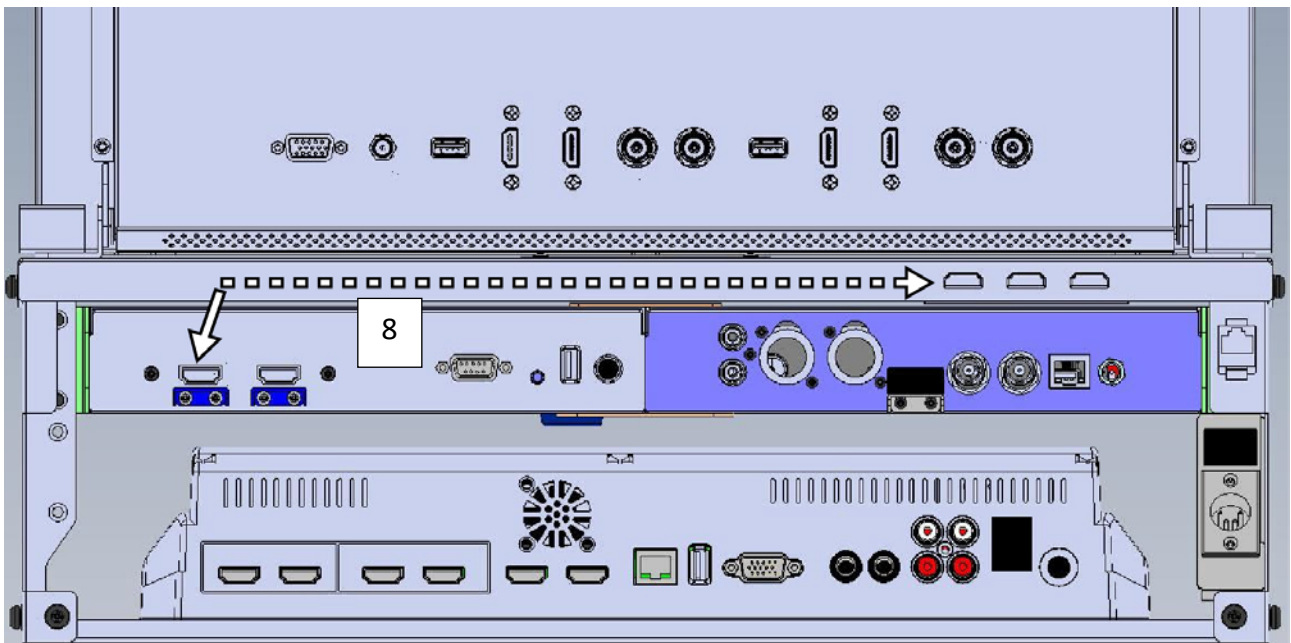

7. First locate the DC jack on the RMK-6 and on the inner side of the DC jack, you should find four DC plug cables attached. Connect Cable No. 1 / 2 / 3 / 4 (DC Plug Cable) to the SE-500HD, TLM-102, NVS-25, and HDR-1 DC jacks respectively and secure by tightening the outer fastening ring.

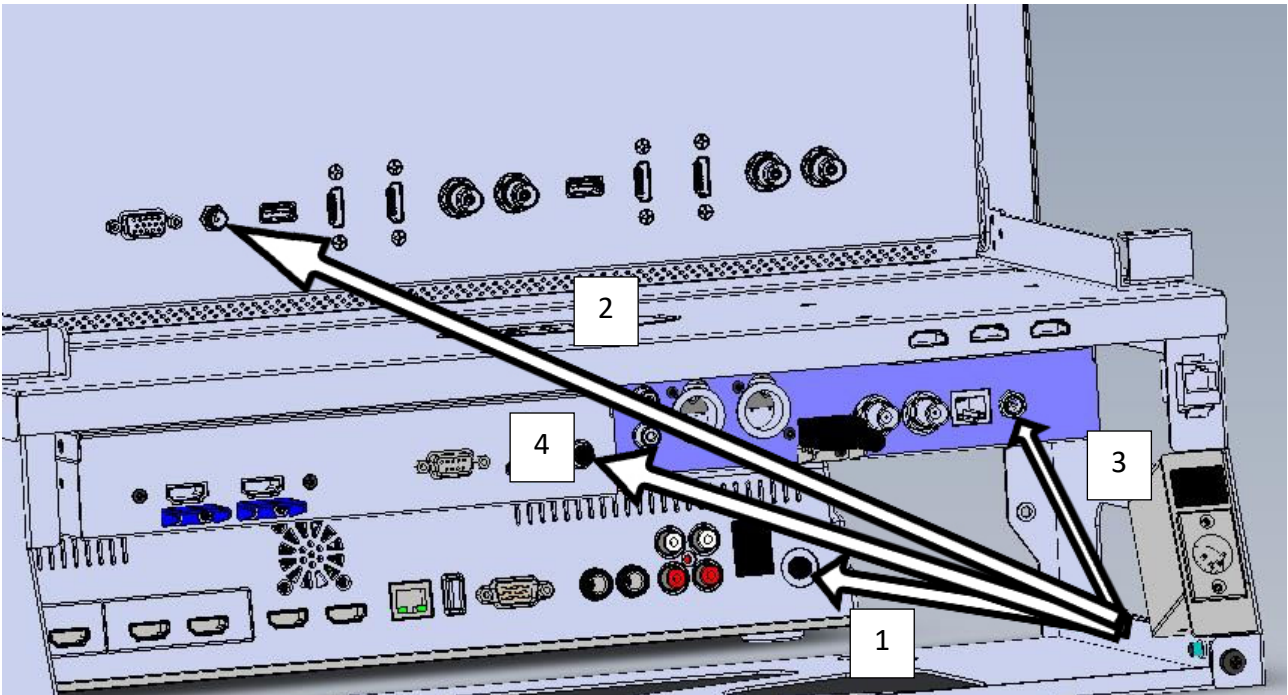

Powering On

Each product built into the GO-500 Studio receives DC power from the power connection on the rear of the RMK-6 unit of the GO-500 STUDIO.

Please ensure the RMK-6 is fed with a DC power supply before attempting to switch on the GO-500 STUDIO.

If a product within the GO-500 STUDIO fails to start after the power switch on the rear of the RMK-6 is switched on please locate the on/off switch for that product which has not yet started.

For further advice on using a product within the GO-500 STUDIO please refer to the related manual.

Powering Off

Before powering off the GO-500 STUDIO via the power switch on the rear of the RMK-6 please ensure the HDR-1 has been stopped.

Packing Away

Carefully fold the 10.1" TLM-102 monitor to its horizontal 1U shipping position. Please remember to secure its position so it cannot move when in transit.

Now return the GO-500 STUDIO to the HC-800 case and the product is ready to be moved.

Dimensions

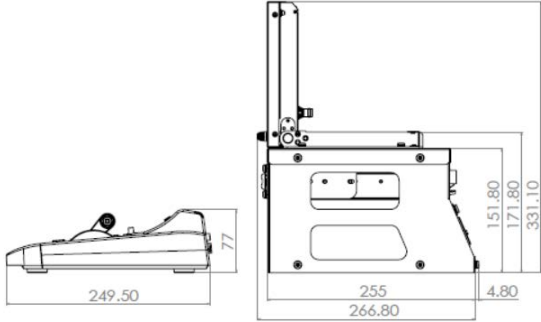
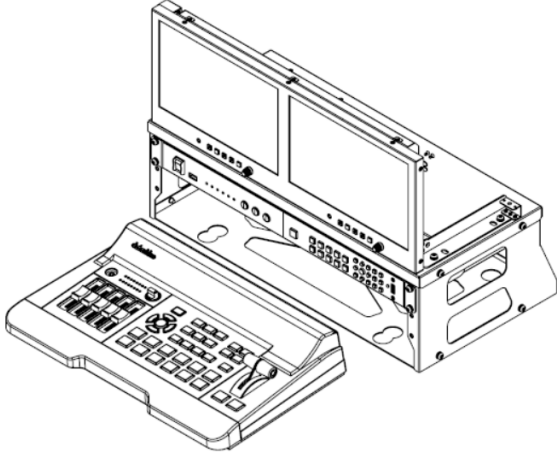
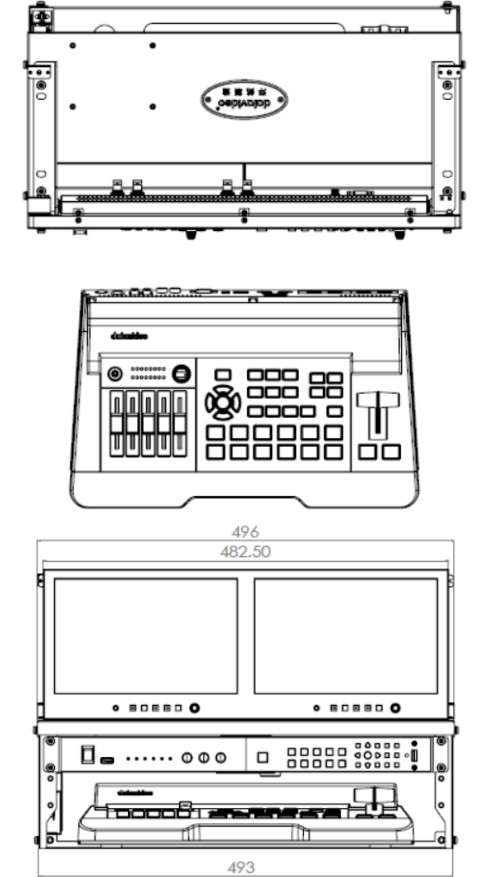
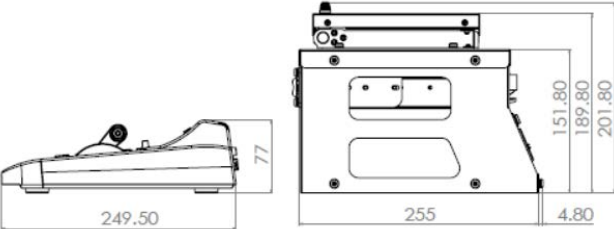
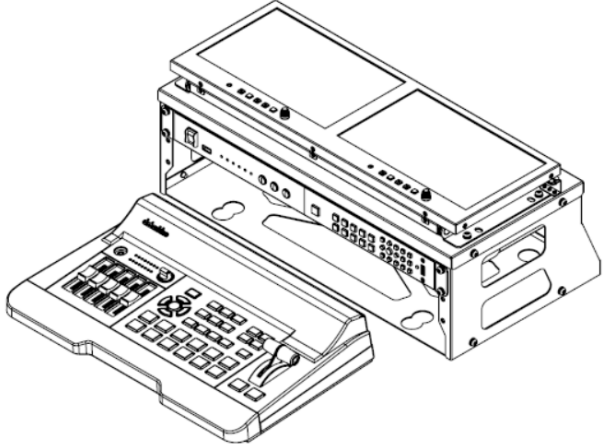
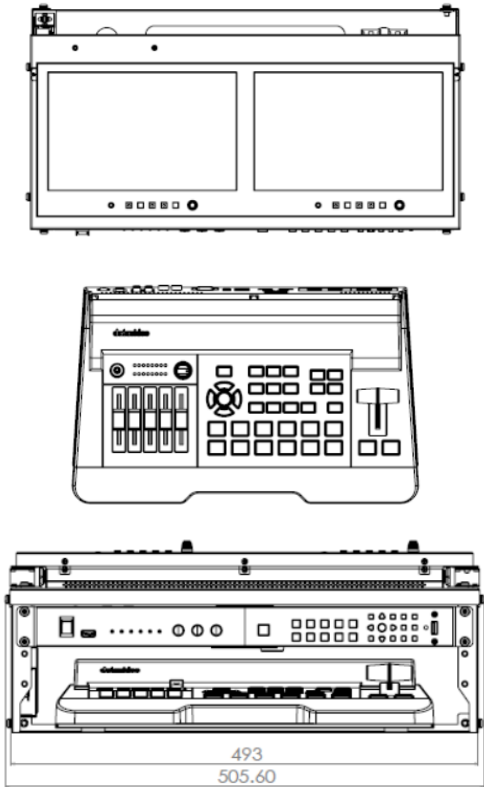

All dimensions in mm.

Weights

The GO-500 STUDIO is heavy – approximately 16.07 Kg – Do not attempt to lift or move it on your own.

A minimum of two people are required to lift or move this product. There are two carry handles on either side of the product, please use these handles to safely share the weight between the people lifting the unit.

Gross Weight (Packed/Pallet)	16.07 Kg
Nett Weight (unpacked unit only)	9.03 Kg
Accessory Kit (Gross packed)	1.08 Kg

Always use a trolley to safely transport the GO-500 STUDIO over distances of 2 Metres or more.

The unit should be always moved and placed in an upright position; do not place or try to move the unit in any other way as damage or injury could result.

Place the GO-500 STUDIO on a strong, stable, flat surface that is capable of supporting the weight. Do not use a folding or single leg table to support the GO-500 STUDIO.

Specifications

The GO-500 STUDIO is a combination of Datavideo products, for the specifications of a particular product please refer to its related manual.

Device	Model
Switcher	SE-500HD
Recorder	HDR-1
Streaming Server	NVS-25
Monitor	TLM-102
Rack Mount Frame	RMK-6

NOTE

Service & Support

It is our goal to make owning and using Datavideo products a satisfying experience. Our support staff is available to assist you to set up and operate your system. Contact your local office for specific support requests. Plus, please visit www.datavideo.com to access our FAQ section.

China Shanghai
Datavideo Technologies China Co
601, Building 10, No. 1228,
Rd. Jiangchang,
Jingan District, Shanghai
Tel: +86 21-5603 6599
Fax: +86 21-5603 6770
E-mail: service@datavideo.cn

China Beijing
Datavideo Technologies China Co
No. 812, Building B, Wankai Center,
No. 316, Wan Feng Road, Fengtai District,
Beijing, China
Tel: +86 10-8586 9034
Fax: +86 10-8586 9074
E-mail: service@datavideo.cn

China Chengdu
Datavideo Technologies China Co
B-823, Meinian square, No. 1388,
Middle of Tianfu Avenue, Gaoxin District,
Chengdu, Sichuan
Tel: +86 28-8613 7786
Fax: +86 28-8513 6486
E-mail: service@datavideo.cn

China Fuzhou
Datavideo Technologies China Co
A1-2318-19 Room, No. 8, Aojiang Road,
Taijiang District, Fuzhou, Fujian, China
Tel: 0591-83211756 · 0591-83210187
Fax: 0591-83211262
E-mail: service@datavideo.cn

China Jinan
Datavideo Technologies China Co
902, No. 1 business building,
Xiangtai Square, No. 129,
Yingxiangshan Road, Shizhong District,
Jinan City, Shandong Province, China
Tel: +86 531-8607 8813
E-mail: service@datavideo.cn

Hong Kong
Datavideo Hong Kong Ltd
G/F., 26 Cross Lane
Wanchai, Hong Kong
Tel: +852-2833-1981
Fax: +852-2833-9916
E-mail: info@datavideo.com.hk

India Noida
Datavideo India Noida
A-132, Sec-63, Noida-201307,
India
Tel: +91-0120-2427337
Fax: +91-0120-2427338
E-mail: sales@datavideo.in

India Kochi
Datavideo India Kochi
2nd Floor- North Wing, Govardhan Building,
Opp. NCC Group Headquarters, Chittoor Road,
Cochin- 682035
Tel: +91 4844-025336
Fax: +91 4844-047696
E-mail: sales@datavideo.in

Netherlands
Datavideo Technologies Europe BV
Floridadreef 106
3565 AM Utrecht,
The Netherlands
Tel: +31-30-261-96-56
Fax: +31-30-261-96-57
E-mail: info@datavideo.nl

Singapore
Datavideo Visual Technology(S) Pte Ltd
No. 178 Paya Lebar Road #06-07
Singapore 409030
Tel: +65-6749 6866
Fax: +65-6749 3266
E-mail: info@datavideovirtualset.com

Singapore
Datavideo Technologies (S) PTE Ltd
No. 178 Paya Lebar Road #06-03
Singapore 409030
Tel: +65-6749 6866
Fax: +65-6749 3266
E-mail: sales@datavideo.sg

Taiwan
Datavideo Technologies Co. Ltd
10F. No. 176, Jian 1st Rd., Chung Ho
District, New Taipei City 235, Taiwan
Tel: +886-2-8227-2888
Fax: +886-2-8227-2777
E-mail: service@datavideo.com.tw

United States
Datavideo Corporation
7048 Elmer Avenue.
Whittier, CA 90602,
U.S.A.
Tel: +1-562-696 2324
Fax: +1-562-698 6930
E-mail: sales@datavideo.com

United Kingdom
Datavideo UK Limited
Brookfield House, Brookfield Industrial
Estate, Peakdale Road, Glossop,
Derbyshire, SK13 6LQ
Tel: +44-1457 851 000
Fax: +44-1457 850 964
E-mail: sales@datavideo.co.uk

France
Datavideo France s.a.r.l.
Cit  Descartes 1, rue Albert Einstein
Champs sur Marne 774477 –
Marne la Vall e cedex 2
Tel: +33-1-60370246
Fax: +33-1-60376732
E-mail: info@datavideo.fr



Please visit our website for latest manual update.
www.datavideo.com/product/GO+500+Studio

datavideo
www.datavideo.com